

Double Spur Gears

Materials

48, 32 DP

STD : Steel 214M15/045M10

ALTERNATIVES : Stainless, Brass, Tufnol or Delrin

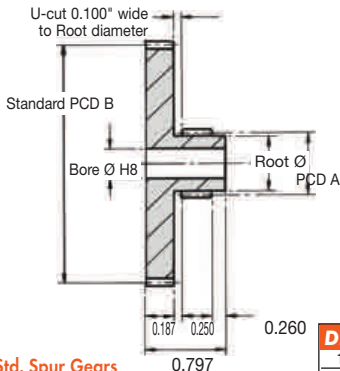

20° Pressure Angle

Other numbers of teeth available

Torque is dependent upon the type of pinions used

For Torque Checks see Std. Spur Gears

For Corrected Teeth see Technical pages

NOTE: Certain sizes may need to be manufactured in 2 pieces

ALL DIMENSIONS IN INCHES

DISCOUNTS	
1 - 5	List Price
6 - 19	- 12%
20 - 39	- 25%
40 - 59	- 33%
60 - 99	- 37%
100 - 200	- 42%

PART NUMBER	PITCH	TEETH		PCD		BORE Ø	ROOT Ø	PRICE EACH
		GEAR A	GEAR A	GEAR B	GEAR B			
DG48-16/48	48	16	0.354	48	1.000	0.187	6.84	£28.69
DG48-16/60	48	16	0.354	60	1.250	0.187	6.84	£29.07
DG48-16/72	48	16	0.354	72	1.500	0.187	6.84	£29.62
DG48-16/96	48	16	0.354	96	2.000	0.187	6.84	£30.09
DG48-16/120	48	16	0.354	120	2.500	0.187	6.84	£30.96
DG48-16/144	48	16	0.354	144	3.000	0.187	6.84	£31.58
DG48-24/60	48	24	0.500	60	1.250	0.250	11.07	£29.07
DG48-24/72	48	24	0.500	72	1.500	0.250	11.07	£29.61
DG48-24/96	48	24	0.500	96	2.000	0.250	11.07	£30.09
DG48-24/120	48	24	0.500	120	2.500	0.250	11.07	£30.96
DG48-24/144	48	24	0.500	144	3.000	0.250	11.07	£31.58
DG32-15/30	32	15	0.500	30	0.937	0.250	9.53	£28.69
DG32-15/45	32	15	0.500	45	1.406	0.250	9.53	£29.07
DG32-15/60	32	15	0.500	60	1.875	0.250	9.53	£29.61
DG32-15/75	32	15	0.500	75	2.344	0.250	9.53	£30.09
DG32-15/90	32	15	0.500	90	2.812	0.250	9.53	£30.96
DG32-15/96	32	15	0.500	96	3.000	0.250	9.53	£31.58
DG32-20/48	32	20	0.625	48	1.500	0.250	13.50	£29.07
DG32-20/56	32	20	0.625	56	1.750	0.250	13.50	£29.61
DG32-20/64	32	20	0.625	64	2.000	0.250	13.50	£30.09
DG32-20/80	32	20	0.625	80	2.500	0.250	13.50	£30.96
DG32-20/96	32	20	0.625	96	3.000	0.250	13.50	£31.58

DP 48,32

Double Gears

18.10



Unit 14, Foxwood Ind. Park, Foxwood Rd. Chesterfield, Derbyshire S41 9RN
Telephone +44(0)1246 268080 Fax +44(0)1246 260003