

Double Spur Gears

Materials

96, 72 DP

STD : Stainless Steel 303S21 (En58)

ALTERNATIVES : Steel, Brass, Tufnol or Delrin

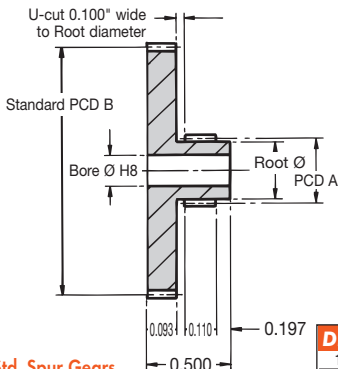

20° Pressure Angle

Other numbers of teeth available

Torque is dependent upon the type of pinions used

For Torque Checks see Std. Spur Gears

For Corrected Teeth see Technical pages

NOTE: Certain sizes may need to be manufactured in 2 pieces

ALL DIMENSIONS IN INCHES

DISCOUNTS

Quantity	List Price
1 - 5	-
6 - 19	- 12%
20 - 39	- 25%
40 - 59	- 33%
60 - 99	- 37%
100 - 200	- 42%

Double Gears DP 96,72

PART NUMBER	PITCH	TEETH GEAR A	PCD GEAR A	TEETH GEAR B	PCD GEAR B	BORE Ø	ROOT Ø	PRICE EACH 1 - 5
DG96-20/40	96	20	0.208	40	0.417	0.093	0.173	£20.06
DG96-20/60	96	20	0.208	60	0.625	0.093	0.173	£21.18
DG96-20/80	96	20	0.208	80	0.833	0.093	0.173	£22.69
DG96-20/100	96	20	0.208	100	1.042	0.093	0.173	£23.66
DG96-20/120	96	20	0.208	120	1.250	0.093	0.173	£24.09
DG96-20/140	96	20	0.208	140	1.458	0.093	0.173	£24.82
DG96-24/60	96	24	0.250	60	0.625	0.125	0.221	£21.18
DG96-24/84	96	24	0.250	84	0.875	0.125	0.221	£22.69
DG96-24/108	96	24	0.250	108	1.125	0.125	0.221	£23.66
DG96-24/132	96	24	0.250	132	1.375	0.125	0.221	£24.09
DG96-24/156	96	24	0.250	156	1.625	0.125	0.221	£24.82
DG72-15/30	72	15	0.222	30	0.417	0.125	0.164	£20.06
DG72-15/45	72	15	0.222	45	0.625	0.125	0.164	£21.18
DG72-15/60	72	15	0.222	60	0.833	0.125	0.164	£22.69
DG72-15/90	72	15	0.222	90	1.250	0.125	0.164	£23.66
DG72-15/120	72	15	0.222	120	1.666	0.125	0.164	£24.09
DG72-15/150	72	15	0.222	150	2.083	0.125	0.164	£24.82
DG72-18/45	72	18	0.250	45	0.625	0.125	0.206	£21.18
DG72-18/63	72	18	0.250	63	0.875	0.125	0.206	£22.69
DG72-18/90	72	18	0.250	90	1.250	0.125	0.206	£23.66
DG72-18/126	72	18	0.250	126	1.750	0.125	0.206	£24.09
DG72-18/162	72	18	0.250	162	2.250	0.125	0.206	£24.82

358



Unit 14, Foxwood Industrial Park, Foxwood Road, Chesterfield, Derbyshire S41 9RN

Telephone +44(0)1246 268080

Fax +44(0)1246 260003