

Materials

Double Spur Gears

STD : *Stainless Steel 303S21 (En58)*

ALTERNATIVES : *Steel, Brass, Tufnol or Delrin*

64 DP

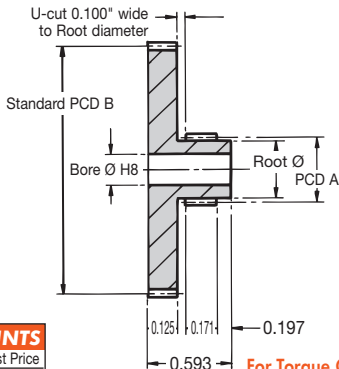

20° Pressure Angle

Other numbers of teeth available

Torque is dependent upon the type of pinions used

DISCOUNTS

1 - 5	List Price
6 - 19	- 12%
20 - 39	- 25%
40 - 59	- 33%
60 - 99	- 37%
100 - 200	- 42%

For Torque Checks see Std. Spur Gears

For Corrected Teeth see Technical pages

NOTE: Certain sizes may need to be manufactured in 2 pieces

ALL DIMENSIONS IN INCHES

PART NUMBER	PITCH	TEETH		P.C.D.		BORE Ø	ROOT Ø	PRICE EACH
		GEAR A	GEAR B	GEAR A	GEAR B			
DG64-16/32	64	16	32	0.265	0.500	0.125	0.200	£20.08
DG64-16/48	64	16	48	0.265	0.750	0.125	0.200	£21.28
DG64-16/64	64	16	64	0.265	1.000	0.125	0.200	£21.89
DG64-16/80	64	16	80	0.265	1.250	0.125	0.200	£22.14
DG64-16/96	64	16	96	0.265	1.500	0.125	0.200	£22.27
DG64-16/112	64	16	112	0.265	1.750	0.125	0.200	£22.96
DG64-20/30	64	20	30	0.312	0.469	0.156	0.263	£21.28
DG64-20/50	64	20	50	0.312	0.781	0.156	0.263	£21.89
DG64-20/70	64	20	70	0.312	1.094	0.156	0.263	£22.14
DG64-20/90	64	20	90	0.312	1.406	0.156	0.263	£22.27
DG64-20/110	64	20	110	0.312	1.718	0.156	0.263	£22.96
DG64-24/30	64	24	30	0.375	0.469	0.187	0.325	£20.45
DG64-24/44	64	24	44	0.375	0.688	0.187	0.325	£21.28
DG64-24/64	64	24	64	0.375	1.000	0.187	0.325	£21.89
DG64-24/84	64	24	84	0.375	1.312	0.187	0.325	£22.14
DG64-24/96	64	24	96	0.375	1.500	0.187	0.325	£22.27
DG64-24/120	64	24	120	0.375	1.875	0.187	0.325	£22.96
DG64-30/45	64	30	45	0.469	0.703	0.187	0.419	£21.28
DG64-30/60	64	30	60	0.469	0.937	0.187	0.419	£21.89
DG64-30/90	64	30	90	0.469	1.406	0.187	0.419	£22.27
DG64-30/120	64	30	120	0.469	1.875	0.187	0.419	£22.96
DG64-30/150	64	30	150	0.469	2.344	0.187	0.419	£24.65

Double Gears DP 64

