

Double Spur Gears

Materials

48, 32 DP

STD : Steel 214M15/045M10

ALTERNATIVES : Stainless, Brass, Tufnol or Delrin

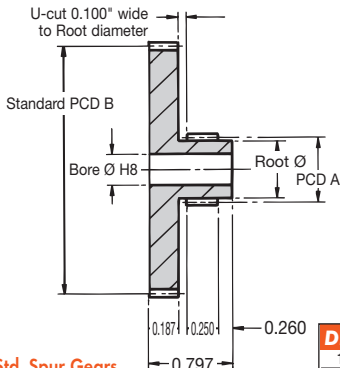

20° Pressure Angle

Other numbers of teeth available

Torque is dependent upon the type of pinions used

For Torque Checks see Std. Spur Gears

For Corrected Teeth see Technical pages

NOTE: Certain sizes may need to be manufactured in 2 pieces

ALL DIMENSIONS IN INCHES

DISCOUNTS

Quantity	List Price
1 - 5	-
6 - 19	- 12%
20 - 39	- 25%
40 - 59	- 33%
60 - 99	- 37%
100 - 200	- 42%

Double Gears DP 48,32

PART NUMBER	PITCH	TEETH GEAR A	PCD GEAR A	TEETH GEAR B	PCD GEAR B	BORE Ø	ROOT Ø	PRICE EACH 1 - 5
DG48-16/48	48	16	0.354	48	1.000	0.187	6.84	£24.34
DG48-16/60	48	16	0.354	60	1.250	0.187	6.84	£24.65
DG48-16/72	48	16	0.354	72	1.500	0.187	6.84	£25.13
DG48-16/96	48	16	0.354	96	2.000	0.187	6.84	£25.54
DG48-16/120	48	16	0.354	120	2.500	0.187	6.84	£26.25
DG48-16/144	48	16	0.354	144	3.000	0.187	6.84	£26.80
DG48-24/60	48	24	0.500	60	1.250	0.250	11.07	£24.65
DG48-24/72	48	24	0.500	72	1.500	0.250	11.07	£25.12
DG48-24/96	48	24	0.500	96	2.000	0.250	11.07	£25.54
DG48-24/120	48	24	0.500	120	2.500	0.250	11.07	£26.25
DG48-24/144	48	24	0.500	144	3.000	0.250	11.07	£26.80
DG32-15/30	32	15	0.500	30	0.937	0.250	9.53	£24.34
DG32-15/45	32	15	0.500	45	1.406	0.250	9.53	£24.65
DG32-15/60	32	15	0.500	60	1.875	0.250	9.53	£25.12
DG32-15/75	32	15	0.500	75	2.344	0.250	9.53	£25.54
DG32-15/90	32	15	0.500	90	2.812	0.250	9.53	£26.25
DG32-15/96	32	15	0.500	96	3.000	0.250	9.53	£26.80
DG32-20/48	32	20	0.625	48	1.500	0.250	13.50	£24.65
DG32-20/56	32	20	0.625	56	1.750	0.250	13.50	£25.12
DG32-20/64	32	20	0.625	64	2.000	0.250	13.50	£25.54
DG32-20/80	32	20	0.625	80	2.500	0.250	13.50	£26.25
DG32-20/96	32	20	0.625	96	3.000	0.250	13.50	£26.80

360



Unit 14, Foxwood Industrial Park, Foxwood Road, Chesterfield, Derbyshire S41 9RN

Telephone +44(0)1246 268080

Fax +44(0)1246 260003