

# Double Spur Gears

Materials

## 16, 12 DP

STD : Steel 214M15/045M10

ALTERNATIVES : Stainless, Brass, Tufnol or Delrin



20° Pressure Angle

Other numbers of teeth available

Torque is dependent upon the type of pinions used.

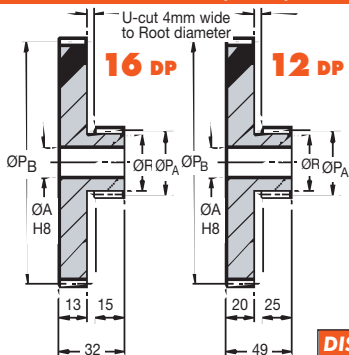

For Torque Checks see Std. Spur Gears

For Corrected Teeth see Technical pages

NOTE: Certain sizes may need to be manufactured in 2 pieces

**ALL DIMENSIONS IN INCHES**

### DISCOUNTS

Quantity	List Price
1 - 5	-
6 - 19	- 12%
20 - 39	- 25%
40 - 59	- 33%
60 - 99	- 37%
100 - 200	- 42%

Double Gears DP 16,12

PART NUMBER	PITCH	TEETH GEAR A	PCD GEAR A	TEETH GEAR B	PCD GEAR B	BORE Ø	ROOT Ø	PRICE EACH 1 - 5
DG16-16/32	16	16	1.000	32	2.000	0.375	0.843	£47.77
DG16-16/48	16	16	1.000	48	3.000	0.375	0.843	£58.12
DG16-16/60	16	16	1.000	60	3.750	0.375	0.843	£69.07
DG16-16/72	16	16	1.000	72	4.500	0.375	0.843	£79.21
DG16-16/96	16	16	1.000	96	6.000	0.375	0.843	£108.55
DG16-16/120	16	16	1.000	120	7.500	0.375	0.843	£181.60
DG16-24/48	16	24	1.500	48	3.000	0.500	1.331	£58.12
DG16-24/60	16	24	1.500	60	3.750	0.500	1.331	£67.99
DG16-24/72	16	24	1.500	72	4.500	0.500	1.331	£77.35
DG16-24/96	16	24	1.500	96	6.000	0.500	1.331	£108.55
DG16-24/120	16	24	1.500	120	7.500	0.500	1.331	£181.61
DG12-15/30	12	15	1.250	30	2.500	0.500	1.036	£62.49
DG12-15/40	12	15	1.250	40	3.333	0.500	1.036	£75.40
DG12-15/45	12	15	1.250	45	3.750	0.500	1.036	£80.85
DG12-15/50	12	15	1.250	50	4.167	0.500	1.036	£87.55
DG12-15/60	12	15	1.250	60	5.000	0.500	1.036	£141.15
DG12-15/70	12	15	1.250	70	5.833	0.500	1.036	£164.94
DG12-20/40	12	20	1.667	40	3.333	0.625	1.451	£75.38
DG12-20/60	12	20	1.667	60	5.000	0.625	1.451	£141.16
DG12-20/80	12	20	1.667	80	6.667	0.625	1.451	£180.87
DG12-20/100	12	20	1.667	100	8.333	0.625	1.451	£260.38
DG12-20/120	12	20	1.667	120	10.000	0.625	1.451	£345.77

362



Unit 14, Foxwood Industrial Park, Foxwood Road, Chesterfield, Derbyshire S41 9RN

Telephone +44(0)1246 268080

Fax +44(0)1246 260003