

## Materials

STD : Steel 214M15/045M10

ALTERNATIVES : Stainless, Brass, Tufnol or Delrin

# Double Spur Gears

## 1, 1.25 MOD

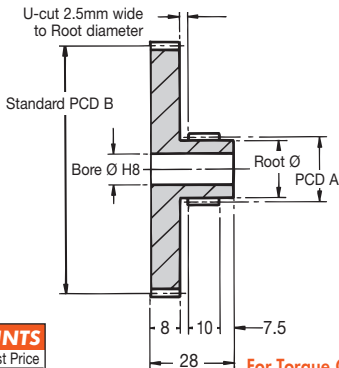

**20° Pressure Angle**

**Other numbers of teeth available**

**Torque is dependent upon the type of pinions used**

### DISCOUNTS

1 - 5	List Price
6 - 19	- 12%
20 - 39	- 25%
40 - 59	- 33%
60 - 99	- 37%
100 - 200	- 42%

For Torque Checks see Std. Spur Gears

For Corrected Teeth see Technical pages

NOTE: Certain sizes may need to be manufactured in 2 pieces

**ALL DIMENSIONS IN MILLIMETRES**

PART NUMBER	TEETH PITCH	TEETH GEAR A	PCD GEAR A	TEETH GEAR B	PCD GEAR B	BORE Ø	ROOT Ø	PRICE EACH 1 - 5
DG1-15/30	1.00	15	16.00	30	30	8	12.05	£25.62
DG1-15/40	1.00	15	16.00	40	40	8	12.05	£26.11
DG1-15/45	1.00	15	16.00	45	45	8	12.05	£26.83
DG1-15/50	1.00	15	16.00	50	50	8	12.05	£27.28
DG1-15/60	1.00	15	16.00	60	60	8	12.05	£27.92
DG1-15/70	1.00	15	16.00	70	70	8	12.05	£28.84
DG1-20/30	1.00	20	20.00	30	30	10	17.05	£26.11
DG1-20/40	1.00	20	20.00	40	40	10	17.05	£26.83
DG1-20/50	1.00	20	20.00	50	50	10	17.05	£27.28
DG1-20/60	1.00	20	20.00	60	60	10	17.05	£27.92
DG1-20/70	1.00	20	20.00	70	70	10	17.05	£28.84
DG1.25-12/24	1.25	12	16.25	24	30	8	11.73	£25.62
DG1.25-12/32	1.25	12	16.25	32	40	8	11.73	£26.46
DG1.25-12/36	1.25	12	16.25	36	45	8	11.73	£26.83
DG1.25-12/40	1.25	12	16.25	40	50	8	11.73	£27.28
DG1.25-12/48	1.25	12	16.25	48	60	8	11.73	£27.92
DG1.25-12/60	1.25	12	16.25	60	75	8	11.73	£28.84
DG1.25-16/24	1.25	16	21.25	24	30	10	16.73	£26.11
DG1.25-16/32	1.25	16	21.25	32	40	10	16.73	£26.83
DG1.25-16/36	1.25	16	21.25	36	45	10	16.73	£27.28
DG1.25-16/48	1.25	16	21.25	48	60	10	16.73	£27.92
DG1.25-16/60	1.25	16	21.25	60	75	10	16.73	£28.84

**Double Gears MOD 1,1.25**

Unit 14, Foxwood Industrial Park, Foxwood Road, Chesterfield, Derbyshire S41 9RN  
 Telephone +44(0)1246 268080 Fax +44(0)1246 260003



**355**