

Materials

Double Spur Gears

STD : *Stainless Steel 303S21 (En58)*

ALTERNATIVES : *Steel, Brass, Tufnol or Delrin*

0.4 MOD

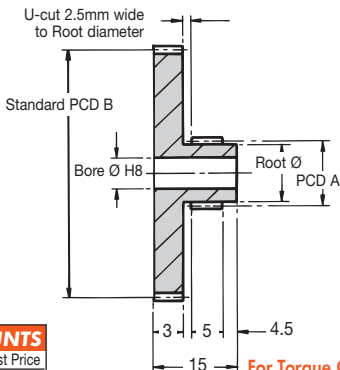

20° Pressure Angle

Other numbers of teeth available

Torque is dependent upon the type of pinions used

DISCOUNTS

1 - 5	List Price
6 - 19	- 12%
20 - 39	- 25%
40 - 59	- 33%
60 - 99	- 37%
100 - 200	- 42%

For Torque Checks see Std. Spur Gears

For Corrected Teeth see Technical pages

NOTE: Certain sizes may need to be manufactured in 2 pieces

ALL DIMENSIONS IN MILLIMETRES

PART NUMBER	PITCH	TEETH GEAR A	PCD GEAR A	TEETH GEAR B	PCD GEAR B	BORE Ø	ROOT Ø	PRICE EACH 1 - 5
DG0.4-16/32	0.4	16	6.80	32	12.80	3	5.13	£20.08
DG0.4-16/48	0.4	16	6.80	48	19.20	3	5.13	£21.28
DG0.4-16/64	0.4	16	6.80	64	25.60	3	5.13	£21.89
DG0.4-16/80	0.4	16	6.80	80	32.00	3	5.13	£22.14
DG0.4-16/96	0.4	16	6.80	96	38.40	3	5.13	£22.27
DG0.4-16/112	0.4	16	6.80	112	44.80	3	5.13	£22.96
DG0.4-20/30	0.4	20	8.00	30	12.00	4	6.43	£21.28
DG0.4-20/50	0.4	20	8.00	50	20.00	4	6.43	£21.89
DG0.4-20/70	0.4	20	8.00	70	28.00	4	6.43	£22.14
DG0.4-20/90	0.4	20	8.00	90	36.00	4	6.43	£22.27
DG0.4-20/110	0.4	20	8.00	110	44.00	4	6.43	£22.96
DG0.4-24/30	0.4	24	9.60	30	12.00	5	8.33	£20.45
DG0.4-24/44	0.4	24	9.60	44	17.60	5	8.33	£21.28
DG0.4-24/64	0.4	24	9.60	64	25.60	5	8.33	£21.89
DG0.4-24/84	0.4	24	9.60	84	33.60	5	8.33	£22.14
DG0.4-24/96	0.4	24	9.60	96	38.40	5	8.33	£22.27
DG0.4-24/120	0.4	24	9.60	120	48.00	5	8.33	£22.96
DG0.4-30/45	0.4	30	12.00	45	18.00	5	10.75	£21.28
DG0.4-30/60	0.4	30	12.00	60	24.00	5	10.75	£21.89
DG0.4-30/90	0.4	30	12.00	90	36.00	5	10.75	£22.27
DG0.4-30/120	0.4	30	12.00	120	48.00	5	10.75	£22.96
DG0.4-30/150	0.4	30	12.00	150	60.00	5	10.75	£24.65

Double Gears MOD 0.4

