

Double Spur Gears

Materials

0.25, 0.3 MOD

STD : Stainless Steel 303S21 (En58)
ALTERNATIVES : Steel, Brass, Tufnol or Delrin

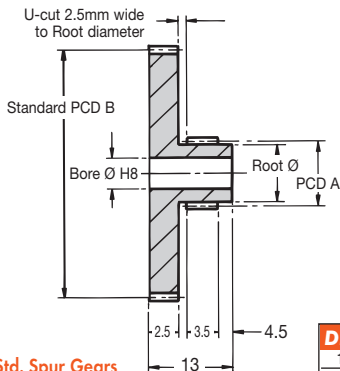

20° Pressure Angle

Other numbers of teeth available

Torque is dependent upon the type of pinions used

For Torque Checks see Std. Spur Gears

For Corrected Teeth see Technical pages

NOTE: Certain sizes may need to be manufactured in 2 pieces

ALL DIMENSIONS IN MILLIMETRES

DISCOUNTS

| Quantity | List Price |
|-----------|------------|
| 1 - 5 | - |
| 6 - 19 | - 12% |
| 20 - 39 | - 25% |
| 40 - 59 | - 33% |
| 60 - 99 | - 37% |
| 100 - 200 | - 42% |

Double Gears MOD 0.25, 0.3

| PART NUMBER | TEETH PITCH | TEETH GEAR A | PCD GEAR A | TEETH GEAR B | PCD GEAR B | BORE Ø | ROOT Ø | PRICE EACH 1 - 5 |
|---------------|-------------|--------------|------------|--------------|------------|--------|--------|------------------|
| DG0.25-20/40 | 0.25 | 20 | 5.00 | 40 | 10.00 | 2.50 | 4.15 | £20.06 |
| DG0.25-20/60 | 0.25 | 20 | 5.00 | 60 | 15.00 | 2.50 | 4.15 | £21.18 |
| DG0.25-20/80 | 0.25 | 20 | 5.00 | 80 | 20.00 | 2.50 | 4.15 | £22.69 |
| DG0.25-20/100 | 0.25 | 20 | 5.00 | 100 | 25.00 | 2.50 | 4.15 | £23.66 |
| DG0.25-20/120 | 0.25 | 20 | 5.00 | 120 | 30.00 | 2.50 | 4.15 | £24.09 |
| DG0.25-20/140 | 0.25 | 20 | 5.00 | 140 | 35.00 | 2.50 | 4.15 | £24.82 |
| DG0.25-24/60 | 0.25 | 24 | 6.00 | 60 | 15.00 | 3.00 | 5.15 | £21.18 |
| DG0.25-24/84 | 0.25 | 24 | 6.00 | 84 | 21.00 | 3.00 | 5.15 | £22.69 |
| DG0.25-24/108 | 0.25 | 24 | 6.00 | 108 | 27.00 | 3.00 | 5.15 | £23.66 |
| DG0.25-24/132 | 0.25 | 24 | 6.00 | 132 | 33.00 | 3.00 | 5.15 | £24.09 |
| DG0.25-24/156 | 0.25 | 24 | 6.00 | 156 | 39.00 | 3.00 | 5.15 | £24.82 |
| DG0.3-20/40 | 0.3 | 20 | 6.00 | 40 | 12.00 | 3.00 | 5.01 | £20.06 |
| DG0.3-20/60 | 0.3 | 20 | 6.00 | 60 | 18.00 | 3.00 | 5.01 | £21.18 |
| DG0.3-20/80 | 0.3 | 20 | 6.00 | 80 | 24.00 | 3.00 | 5.01 | £22.69 |
| DG0.3-20/100 | 0.3 | 20 | 6.00 | 100 | 30.00 | 3.00 | 5.01 | £23.66 |
| DG0.3-20/120 | 0.3 | 20 | 6.00 | 120 | 36.00 | 3.00 | 5.01 | £24.09 |
| DG0.3-20/140 | 0.3 | 20 | 6.00 | 140 | 42.00 | 3.00 | 5.01 | £24.82 |
| DG0.3-24/60 | 0.3 | 24 | 7.20 | 60 | 16.00 | 3.00 | 6.21 | £21.18 |
| DG0.3-24/84 | 0.3 | 24 | 7.20 | 84 | 25.20 | 3.00 | 6.21 | £22.69 |
| DG0.3-24/108 | 0.3 | 24 | 7.20 | 108 | 32.40 | 3.00 | 6.21 | £23.66 |
| DG0.3-24/132 | 0.3 | 24 | 7.20 | 132 | 39.16 | 3.00 | 6.21 | £24.09 |
| DG0.3-24/156 | 0.3 | 24 | 7.20 | 156 | 46.80 | 3.00 | 6.21 | £24.82 |

352



Unit 14, Foxwood Industrial Park, Foxwood Road, Chesterfield, Derbyshire S41 9RN

Telephone +44(0)1246 268080

Fax +44(0)1246 260003