

Bevel Gears 1:1

Materials

3 - 6 MOD

STD : Steel 080M40 (En8)
Straight Cut - Gleason System



N.B. Induction hardening will double the torque figures for steel

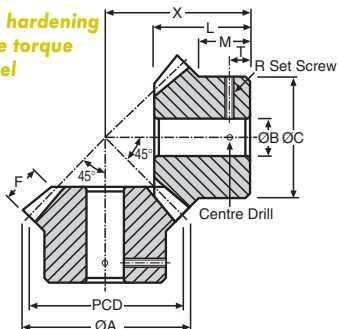

20° Pressure Angle

Other numbers of teeth available

DISCOUNTS

Quantity	List Price
1 - 5	-
6 - 19	- 5%
20 - 39	- 10%
40 - 59	- 15%
60 - 99	- 20%
100 - 200	- 25%

TORQUE CHECK	20 teeth x 1000 rpm			
	3 MOD	4 MOD	5 MOD	6 MOD
TORQUE Nm.	6.00	8.83	16.00	25.00
K.W.	0.63	0.93	1.70	2.60

PART NUMBER	TEETH	MOD	PCD	X	ØA	ØB	ØC	L	M	F	R	T	PRICE EA.
													1-5
B3-16	16		48.00	44.00	52.24	15	40.00	29.08	16.00	11	M5	8	£35.37
B3-19	19	3	57.00	49.00	61.24	16	50.00	31.01	17.02	13	M5	9	£44.85
B3-26	26		78.00	65.00	82.24	18	64.00	40.03	19.03	18	M6	10	£60.21
B3-30	30		90.00	68.50	94.24	20	76.00	39.65	16.51	21	M6	8	£65.12
B4-16	16		64.00	55.50	69.66	15	50.00	35.81	16.49	15	M5	8	£50.65
B4-19	19	4	76.00	65.00	81.66	18	62.50	41.43	20.24	18	M6	10	£63.11
B4-26	26		104.00	82.00	109.66	22	85.00	48.69	20.50	24	M6	10	£71.42
B4-30	30		120.00	90.00	125.66	25	102.00	51.51	21.00	28	M8	11	£77.94
B5-16	16		80.00	70.00	87.10	18	60.00	46.13	20.00	20	M8	11	£82.02
B5-20	20	5	100.00	80.00	107.10	20	80.00	49.04	21.50	24	M8	12	£87.18
B5-25	25		125.00	100.00	132.10	25	80.00	59.47	24.00	28	M10	14	£92.57
B5-30	30		150.00	114.00	157.10	30	100.00	65.87	26.00	35	M10	15	£97.08
B6-16	16		96.00	80.00	104.52	25	75.00	50.10	22.00	22	M10	12	£100.81
B6-20	20	6	120.00	90.00	128.52	30	96.00	52.32	18.50	28	M10	12	£105.37
B6-25	25		150.00	115.00	158.52	35	100.00	67.29	24.00	35	M10	14	£110.06
B6-30	30		180.00	130.00	188.52	35	120.00	72.24	28.00	42	M10	16	£116.96

Bevel Gears Steel MOD 3-6

218



Unit 14, Foxwood Industrial Park, Foxwood Road, Chesterfield, Derbyshire S41 9RN
Telephone +44(0)1246 268080 Fax +44(0)1246 260003

Materials

STD : White Delrin
Straight Cut - Gleason System

Bevel Gears 1:1

3 - 6 MOD

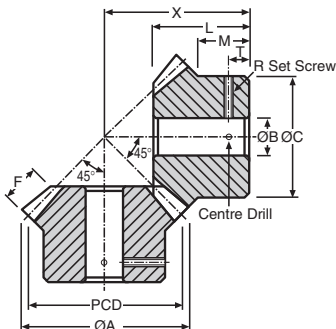

20° Pressure Angle

Other numbers of teeth available

DISCOUNTS

1 - 5	List Price
6 - 29	- 5%
30 - 99	- 10%
100 - 399	- 15%
400 - 999	- 20%
1000 - 5000	- 25%

TORQUE CHECK	20 teeth x 1000 rpm			
	3 MOD	4 MOD	5 MOD	6 MOD
TORQUE Nm.	1.93	2.84	5.00	8.00
K.W.	0.20	0.30	0.54	0.85

PART NUMBER	TEETH	MOD	PCD	X	ØA	ØB	ØC	L	M	F	R	T	PRICE EA. 1-5
ZB3-16	16	3	48.00	44.00	52.24	15	40.00	29.08	16.00	11	M5	8	£34.96
ZB3-19	19		57.00	49.00	61.24	16	50.00	31.01	17.02	13	M5	9	£44.75
ZB3-26	26		78.00	65.00	82.24	18	64.00	40.03	19.03	18	M6	10	£59.39
ZB3-30	30	90.00	68.50	94.24	20	76.00	39.65	16.51	21	M6	8	£64.26	
ZB4-16	16	4	64.00	55.50	69.66	15	50.00	35.81	16.49	15	M5	8	£47.31
ZB4-19	19		76.00	65.00	81.66	18	62.50	41.43	20.24	18	M6	10	£62.99
ZB4-26	26		104.00	82.00	109.66	22	85.00	48.69	20.50	24	M6	10	£71.28
ZB4-30	30	120.00	90.00	125.66	25	102.00	51.51	21.00	28	M8	11	£77.71	
ZB5-16	16	5	80.00	70.00	87.10	18	60.00	46.13	20.00	20	M8	11	£82.02
ZB5-20	20		100.00	80.00	107.10	20	80.00	49.04	21.50	24	M8	12	£87.18
ZB5-25	25		125.00	100.00	132.10	25	80.00	59.47	24.00	28	M10	14	£92.57
ZB5-30	30	150.00	114.00	157.10	30	100.00	65.87	26.00	35	M10	15	£97.08	
ZB6-16	16	6	96.00	80.00	104.52	25	75.00	50.10	22.00	22	M10	12	£100.81
ZB6-20	20		120.00	90.00	128.52	30	96.00	52.32	18.50	28	M10	12	£105.37
ZB6-25	25		150.00	115.00	158.52	35	100.00	67.29	24.00	35	M10	14	£110.06
ZB6-30	30		180.00	130.00	188.52	35	120.00	72.24	28.00	42	M10	16	£116.96

Bevel Gears Plastic MOD 3-6

