

**Output Torque Range**  
26Nm to 128Nm

**Ratio**  
1:1 - 2:1

**Gearboxes**

**HPCBLHT70 Heavy Duty, Hardened Bevel & Bevel Tee**

<b>WEIGHT</b>	7.20 Kg
<b>BACKLASH (approx.)</b>	1° approx
<b>HOURS LIFE</b>	12000 hr
<b>MAX INPUT SPEED</b>	3000 rpm
<b>MATERIAL:</b>	
<b>CASE MAT'L</b>	Aluminium HE30TF
<b>BEVEL MAT'L</b>	655M13 Case/HD (EN36)
<b>GREASED FOR LIFE</b>	Shell Alvania

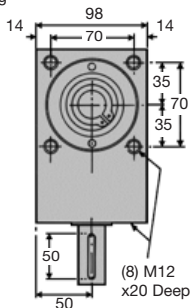
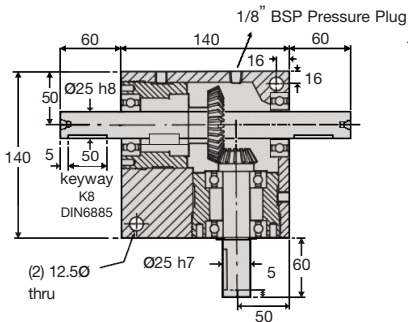

N.m.	RPM Input	Reduction ratio	
		1:1	2:1
Output Torque	3000	43	26
	2000	47	30
	1000	51	34
	500	64	38
	100	85	51
	50	94	60
	10	128	77

DISCOUNTS	
1 - 5	List Price
6 - 19	-5%
20 - 49	-10%
50 - 99	-15%
100 +	-20%

PART NUMBER	Ratio	% Efficiency	Max Input Speed	Module	PRICE EACH 1-5
HPCBLHT70-1	1:1	88	3000	2	£849.00
HPCBLHT70-2	2:1	88	3000	2	£849.00

**Other Info.**

Testing in your application is necessary.

You will need to assess duty, cycles and confirm gearbox suitability with your own calculations. Torque figures are to be used for guidance only.

Unit 14, Foxwood Industrial Park, Foxwood Rd. Chesterfield, Derbyshire S41 9RN  
Telephone +44(0)1246 268080 Fax +44(0)1246 260003



**1.47**

**Bevel Gearboxes**

HEAVY DUTY, HARDENED BEVEL & BEVEL TEE

HPCBLHT70